

- Costruzione in alluminio e vetro temprato IP67/IP69K
  - Resistente ad acqua, vibrazioni ed oli industriali
  - Lunghezza 400/600mm
  - Orientabile 120°
  - Temperatura max operativa +60°C
- Body in aluminum and tempered glass IP67/IP69K
  - Water, vibration and oil resistant
  - Length 400/600mm
  - Adjustable 120°
  - Max operative temperature +60°C



MODELLI Model List	Codice Code	Potenza Power	Tensione d'ingresso Input voltage	Flusso luminoso Luminous flux	Fascio luminoso Beam	Dimensioni Case size W x H x D	Peso Weight
DTS LED - QMFLN 300	3479000630	12.5 W	24 VDC	851 lm	120°	310 x 51 x 67.4 mm	800 g
DTS LED - QMFLN 600	3479000660	25 W		1719 lm		620 x 51 x 67.4 mm	1490 g

Grado di protezione / Protection level	IP67/69K
Temperatura operativa Operating temperature	-30...+60 °C
Durata / Lifespan	50000 h
CCT	5500-6000 K
CRI	≥80Ra
PF	K ≥80 Ra
Connessione / Connection	Cavo/Cable 1m Opzionale/Option M12 4pin
Modalità di montaggio Mounting method	Staffa regolabile Adjustable bracket

La serie DTS-LED QMFLN ha un robusto corpo di alluminio ed è protetta da un vetro temprato raggiungendo un grado di protezione IP67/IP69K. È particolarmente indicata nell'illuminazione di macchinari, illuminazione di celle frigorifere, industria alimentare, industria farmaceutica, ecc. Il collegamento avviene con cavo di 1m. La staffa fornita a corredo permette un'ampia regolazione del fascio luminoso.

DTS-LED QMFLN is made by strong aluminum material and it is protected by a tempered glass offering the IP67/IP69K degree of protection. It is then suitable to machinery lighting in various manufacturing sectors, from machine tools to pharmaceuticals, from packaging to food industries. The device comes with a 1m wiring for a easy and fast connection to the existing power network. Thanks to the included stainless steel bracket the light can be oriented as needed.

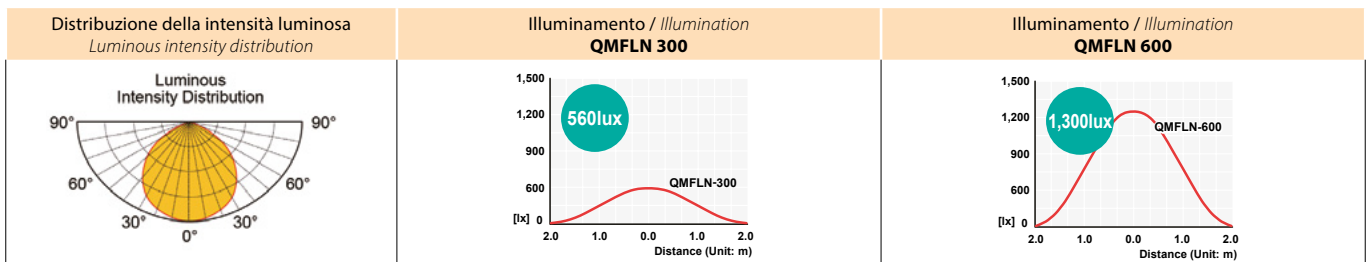

### Dimensioni / Dimensions

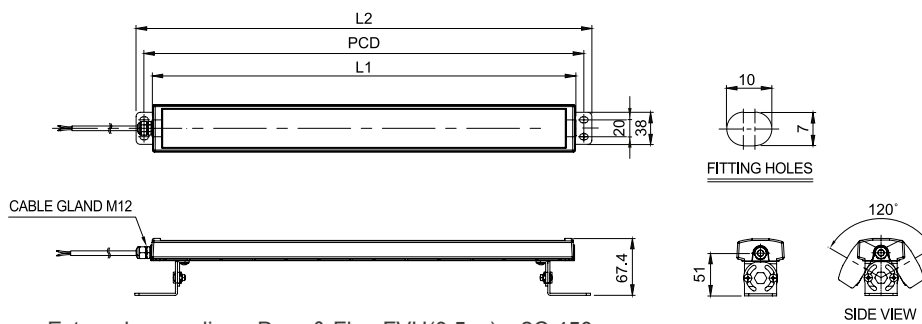

MODEL	L1	PCD	L2
QMFLN - 300	290	310	330
QMFLN - 600	600	620	640

External power line - Dura & Flex-FVU(0.5sq) x 2C 450mm