

Large Payloads Robot

ER210-2700

EFORT

ER210-2700 is a large payloads robot.
Maxium payload 210 kg with maxium reach 2674 mm.

Highlights

Thanks to the high stiffness structure, with high-speed intelligent palletizing application software, the takt is improved by 20%, bring customers more efficiency;
Multiple specific application software could be integrated, with soft PLC and a variety of field bus interface, which enable customers easily face various application challenges;
High performance collision detection function helps safety realization.

Applications

It can be widely used in spot welding, handling, palletizing, machine tending and other applications.

Industries

Suitable for auto parts, photovoltaic, food and beverage, building materials, logistics and warehousing and other industries.

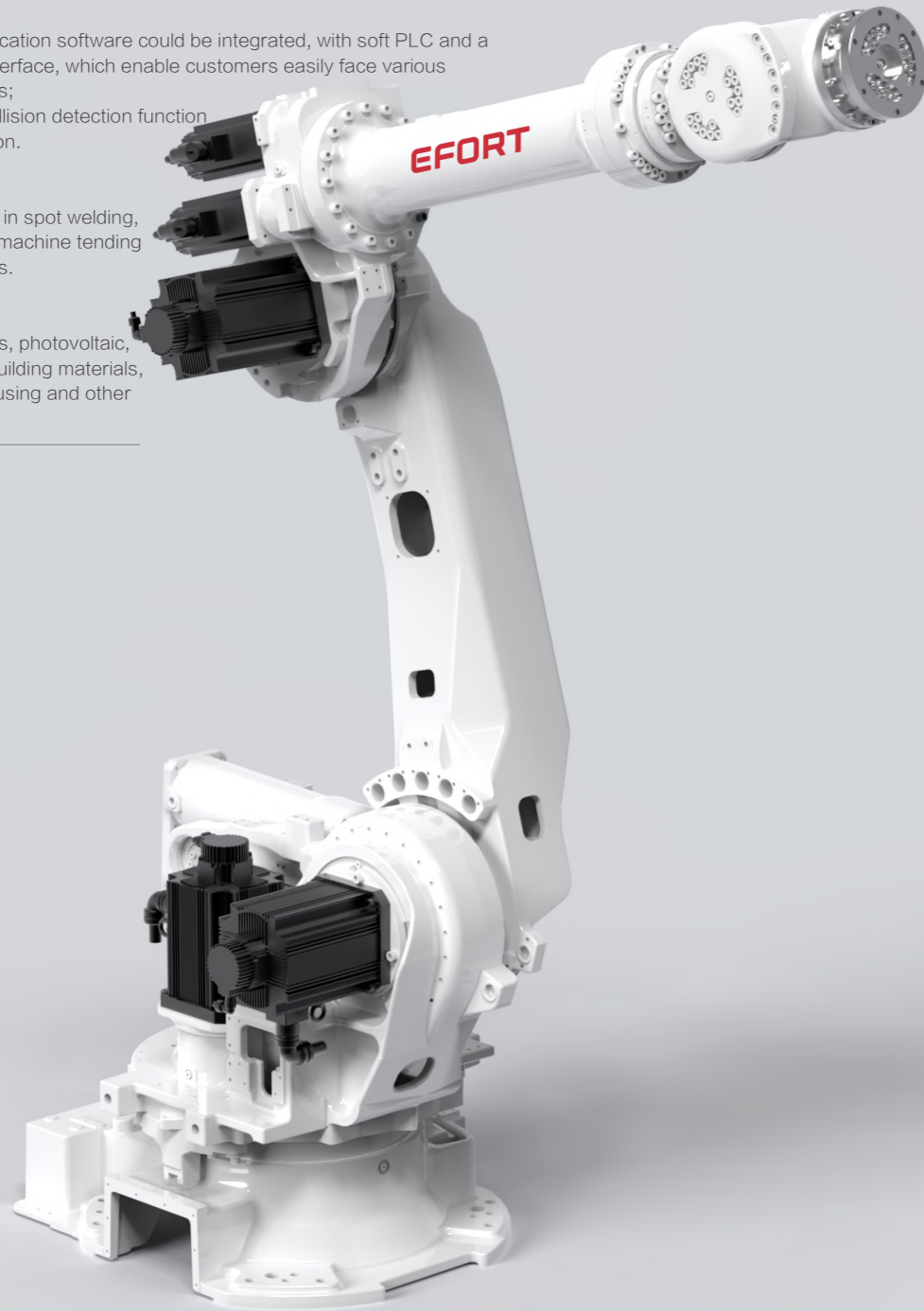

SPECIFICATIONS

Model	ER210-2700	
Type	Articulated Type	
Controlled Axes	6 Axes	
Wrist Payload	210 kg	
Repeatability	± 0.1 mm	
Robot Weight	1110 kg	
Reach	2674mm	
Robot IP Grade	IP65	
Cabinet IP Grade	IP54	
Drive Method	Electric servo drive by AC servo motor	
Installation	Floor	
Environment Requirements	Ambient Temperature	0~45 °C
	Humidity	< 80%/40°C (No Condensation)
	Vibration Acceleration	4.9 m/s ² (< 0.5 G)

Allowable Torque	J4	1337 N.m
	J5	1337 N.m
	J6	720 N.m
Allowable Moment of Inertia	J4	141.1 kg.m ²
	J5	141.1 kg.m ²
	J6	79 kg.m ²
Maximum Speed	J1	100°/sec
	J2	90°/sec
	J3	85°/sec
	J4	109°/sec
	J5	105°/sec
	J6	200°/sec
Motion Range	J1	± 180°
	J2	+60°/-80°
	J3	+90°/-83°
	J4	± 360°
	J5	± 120°
	J6	± 360°

OPERATING SPACE

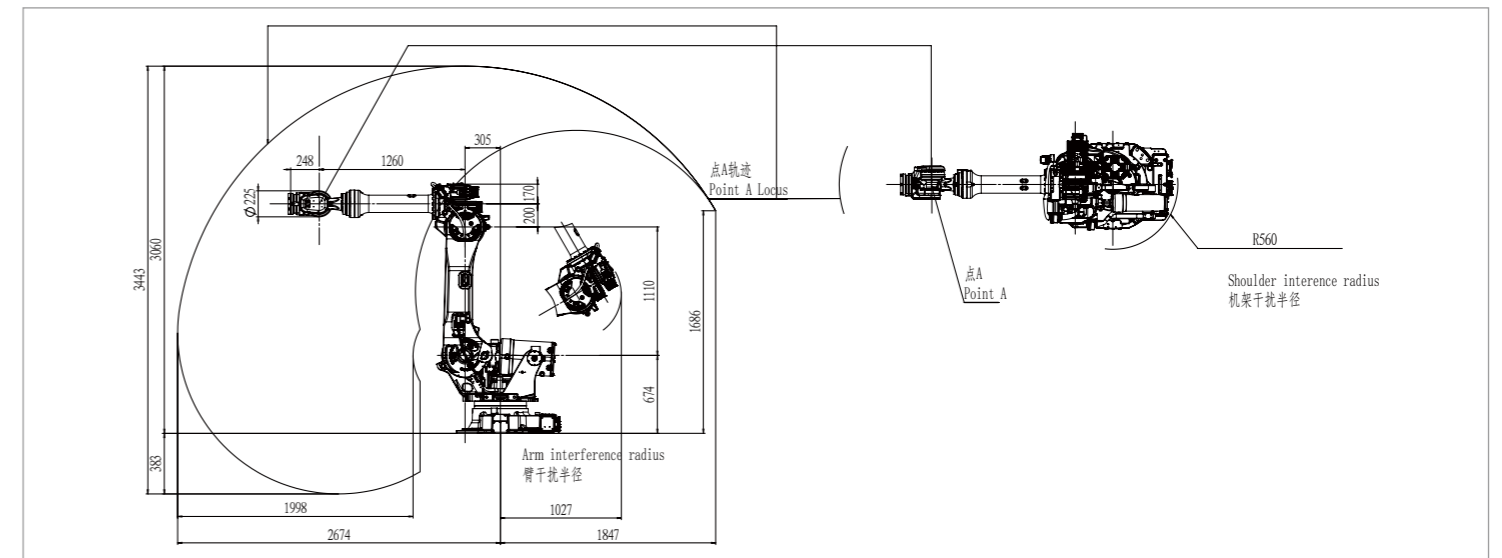

BASE MOUNTING SIZE

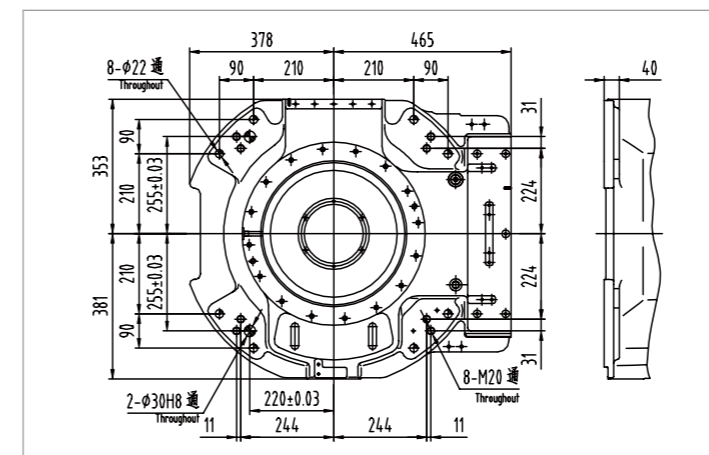

END FLANGE MOUNTING SIZE

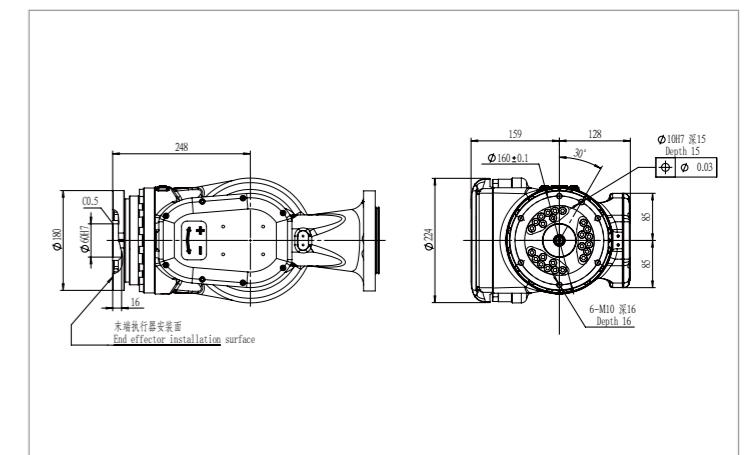

EFORT INTELLIGENT EQUIPMENT CO.,LTD.

PHONE: (00 86) 400-052-8877

ADDRESS: No.96 East WanChun Road, JiuJiang Economic

Development Zone, Wuhu, Anhui, China

WWW.EFORT.COM.CN